



# 229H SERIES

## GENERAL INDUSTRIAL LIGHTING

DATE:		PROJECT MGR:	
JOB:			
CAT#:			
TYPE:			



- TASK
- PAINTBOOTH
- VAPOR DUST
- VAPOR
- WET DAMP
- MARINE
- EXPLOSION PROOF
- HID
- INSPECTION
- PORTABLE LIGHTING
- MOUNTING
- PHOTOMETRY
- LAMPS BALLASTS
- INFO
- CUSTOM
- ASK THE EXPERT

### DESCRIPTION

Fabricated from prepainted cold rolled steel, the Series 229H is ideal for a variety of industrial lighting needs. A unique hinged ballast cover provides easy access to internal wiring and ballast for installation or service without the need to remove lamps. The Series 229H uses a 5 Ft. 3-wire whip which reduces installation time by not having to open the fixture. Available in T12, T8, T8HO, or T5HO lamps.

### SPECIFICATIONS

**LISTINGS:** UL1598



**FEATURES:** Heavy Duty open industrial fixture.  
Hinged ballast plate allows for the fixture to be lamped prior to installation.  
Sturdy 20-gauge steel with durable prepainted white enamel finish.

**ELECTRICAL:** Utilizes 32, 40, 44, and 54 Watt 4' lamps.  
Available in Universal, 120, 277 and 347 Volt electronic ballasts.  
(Other voltages available, consult factory)

**APPLICATIONS:** General Lighting

**OPTIONS:** **All Options Ordered Separately**  
A: Pattern 12 acrylic diffuser available in 32W T8 only.  
WG: Zinc plated wire guard  
PC: Post Painted Polyester White Powder Coat Paint  
EM: Emergency Battery Backup Ballast  
120 or 277V **MUST SPECIFY**  
2 or 3 Lamp options.  
Installed lamps (lamps sold separately)

- **MOUNTING KITS - Ordered Separately**  
Chain Hanging Kit - #3218

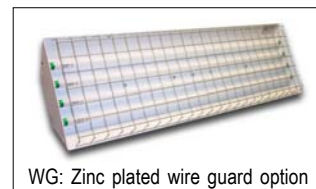



# 229H SERIES

## GENERAL INDUSTRIAL LIGHTING

### PART NUMBERS

- TASK
- PAINTBOOTH
- VAPOR DUST
- VAPOR
- WET DAMP
- MARINE
- EXPLOSION PROOF
- HID
- INSPECTION
- PORTABLE LIGHTING
- MOUNTING
- PHOTOMETRY
- LAMPS BALLASTS
- INFO
- CUSTOM
- ASK THE EXPERT

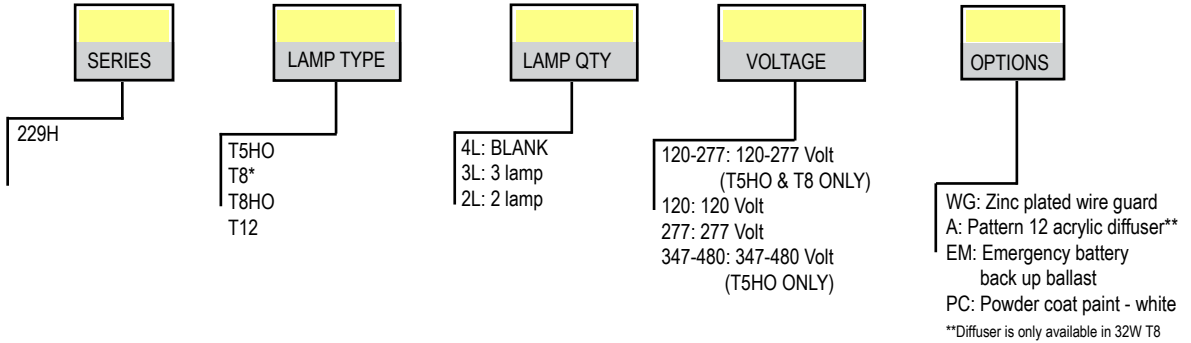

LAMPS SOLD SEPARATELY  
 (Multiple voltages available, consult factory)  
 \*Normally stocked fixture  
 (Consult factory for lead time on non-stock products.)



### DIMENSIONS

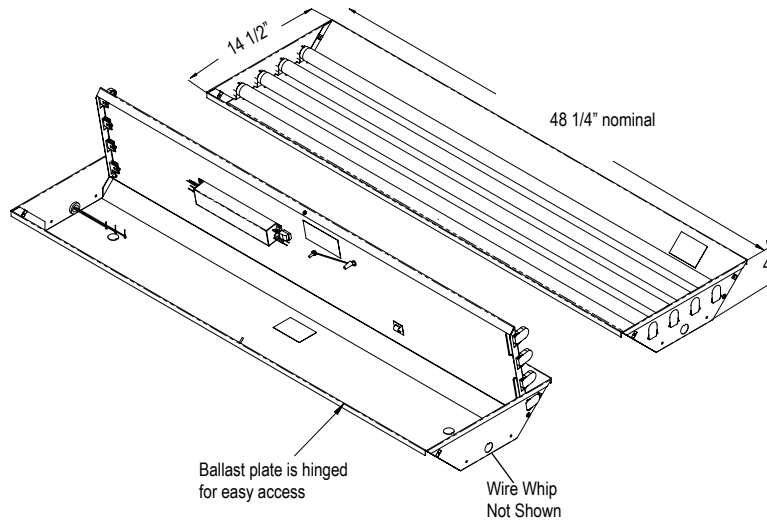

### MOUNTING - ORDERED SEPARATELY

PN: 3218 Chain hang kit

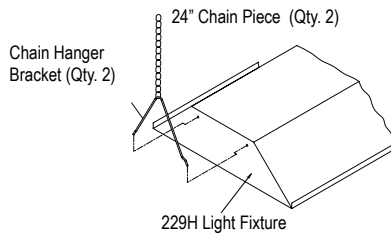



# MOUNTING

FOR LDPI, INC. FIXTURES

## 229H Series

PN: 3218 Chain hang kit

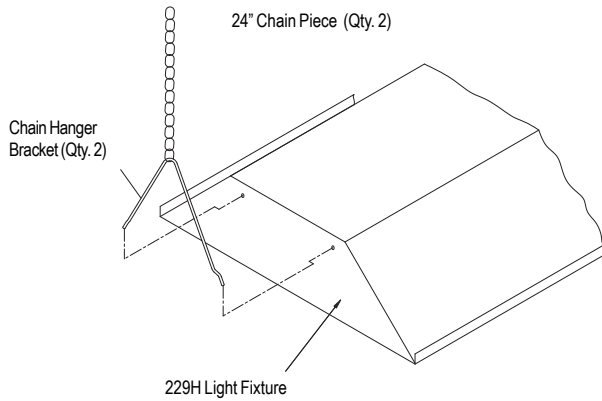

TASK

PAINTBOOTH

VAPOR  
DUST

VAPOR

WET  
DAMP

MARINE

EXPLOSION  
PROOF

HID

INSPECTION

PORTABLE  
LIGHTING

**MOUNTING**

PHOTOMETRY

LAMPS  
BALLASTS

INFO

CUSTOM

ASK THE  
EXPERT